

| | | | | | | | | | |
|---------------|----------------|---------------------|----------------------|---------------|----------------|-------------|---------------------------|---------------------|--------------------------|
| | | | | | | | | | |
| Left Side:1Pc | Right Side:1Pc | Left Back Plate:1Pc | Right Back Plate:1Pc | Left Door:1Pc | Right Door:1Pc | Shelf: 4Pcs | Outer Bottom Skirting:1Pc | Shelf Holder:16Pcs | Key:1 Set |
| | | | | | | | Inner Bottom Skirting:1Pc | Adjusting Feet:4Pcs | "7"Shape Door Pivot:4Pcs |

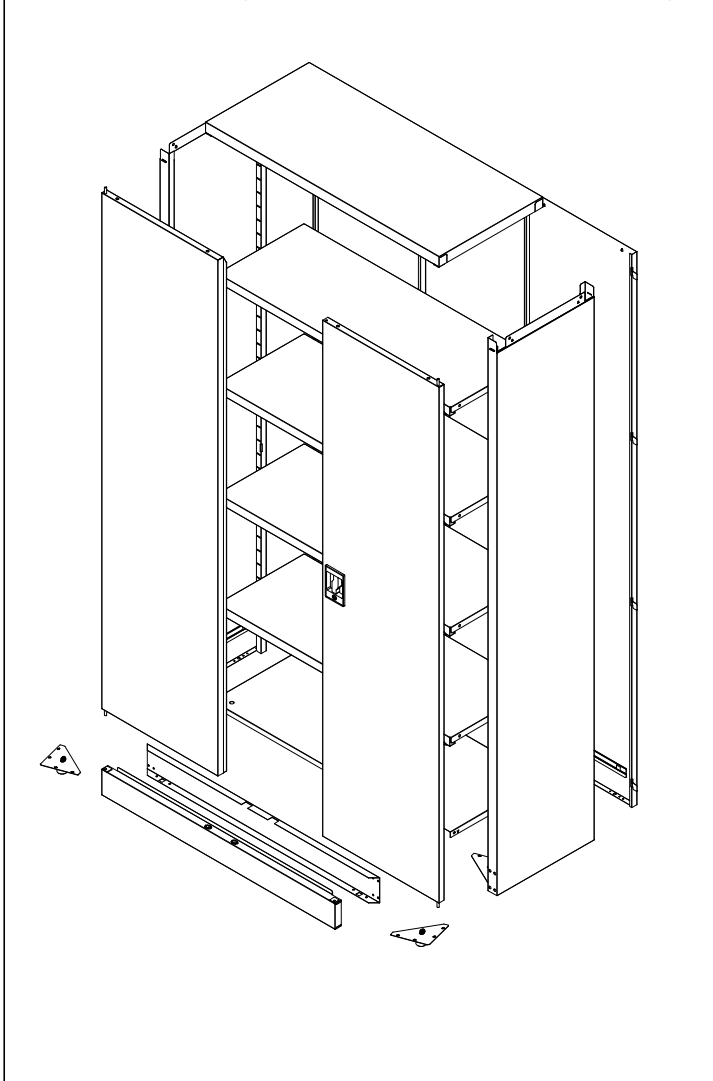

①

Connect the left side and left back plate together.

②

Connect the right back plate and left back plate together.

③

Connect the right side and right back plate together.

④

Fix the inner bottom skirting with M4 screws. (Fix the screws into the inside 4 holes)

⑤

Put the outer bottom skirting onto the inner bottom panel.

⑥

Install the bottom plate. (The front border of bottom plate should cover the upper border of outer bottom skirting)

⑦

Install the top plate from front to back. (fix the front border with clip on the upper corner of side plate.)

⑧

Place the shelf holders to the required height, then place the shelves.

⑧

Install the doors.

⑧

Install the adjusting feet with self-tapping screw (5x12)

⑧

Adjust the feet with shape "-" screwdriver and place the end caps.

⑧

Ajust each part till fit well after installation.