

Top Plate:1pc

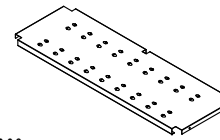

Shelf:3pcs

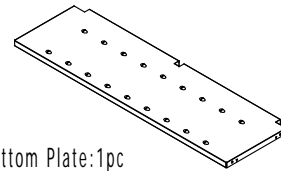

Bottom Plate:1pc



Hanging Plate:36pcs



Self-tapping Screw  
(5x12):15pcs

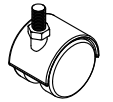

Caster:4pcs

Side Plate(left):1pc

Side Plate(right):1pc

Back Plate(left):1pc

Back Plate(right):1pc

Front Frame:1pc

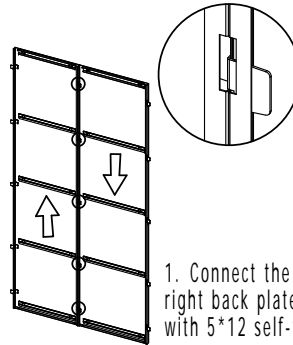
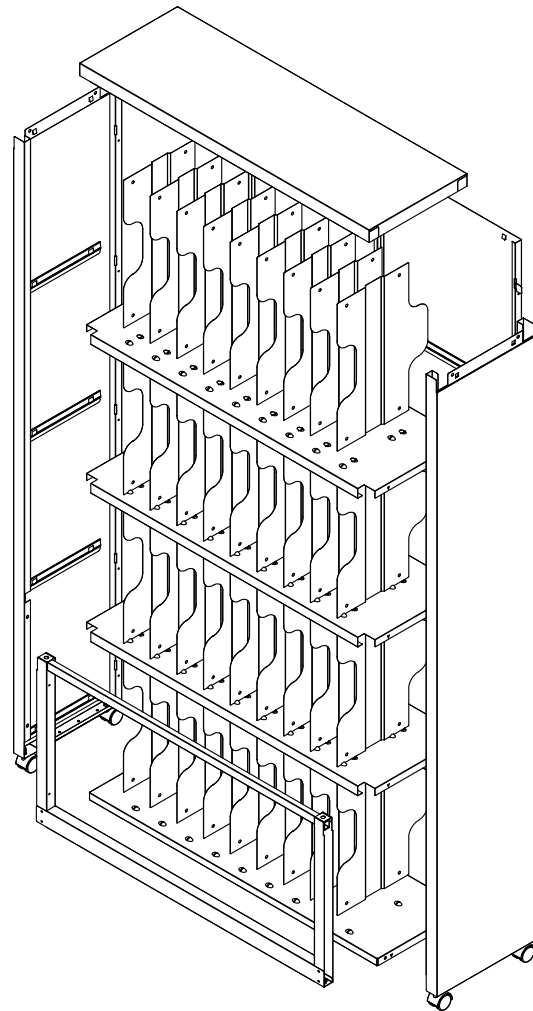

1. Connect the left and right back plate together with 5\*12 self-tapping screws.

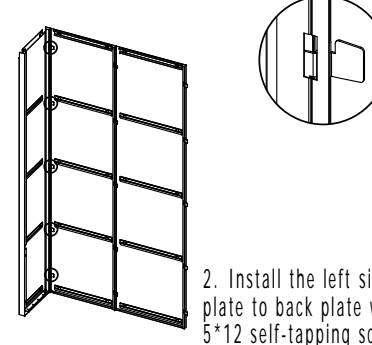

2. Install the left side plate to back plate with 5\*12 self-tapping screws.

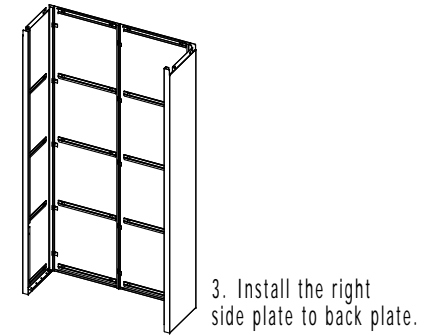

3. Install the right side plate to back plate.

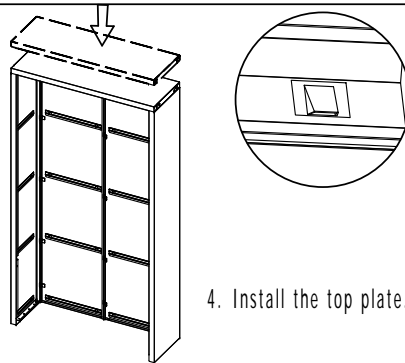

4. Install the top plate.

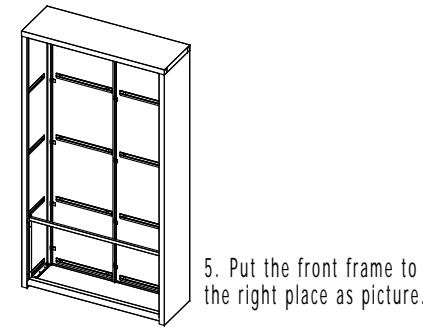

5. Put the front frame to the right place as picture.

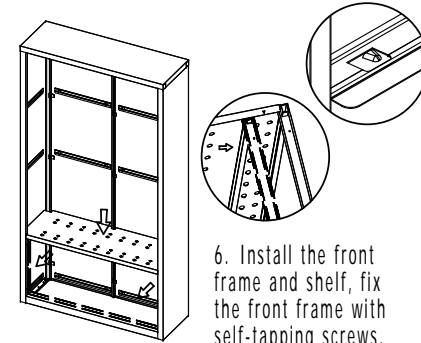

6. Install the front frame and shelf, fix the front frame with self-tapping screws.

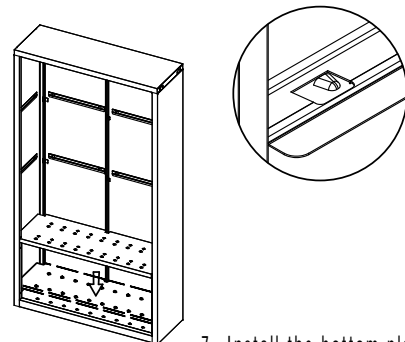

7. Install the bottom plate.

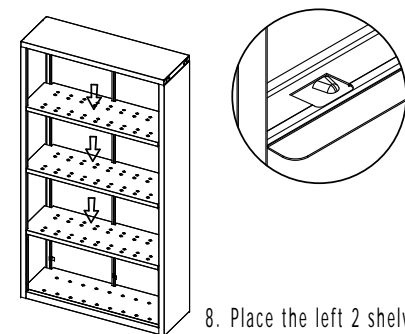

8. Place the left 2 shelves one by one.

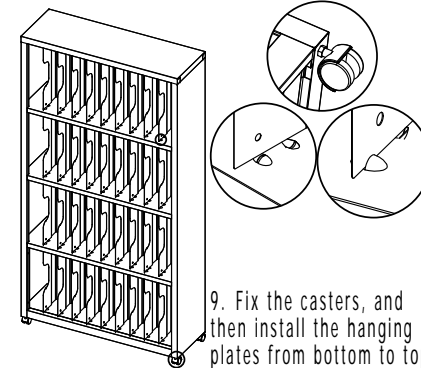

9. Fix the casters, and then install the hanging plates from bottom to top.